

PRESSE IDRAULICHE

HYDRAULIC PRESSES
PRESSES HYDRAULIQUES
HYDRAULISCHE PRESSEN

Made in Italy 

**6•10
TON**



ART. 152

PRESSE IDRAULICHE DA BANCO

HYDRAULIC STAND PRESSES

PRESSES HYDRAULIQUES D'ETABLI

HYDRAULISCHE TISCHPRESSEN

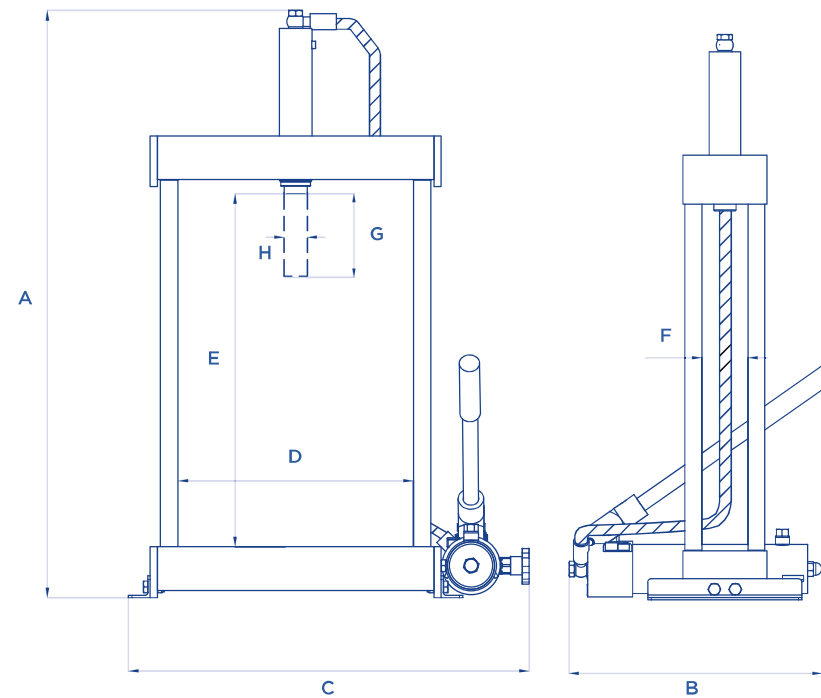

ART.	TON	A mm	B mm	C mm	D mm	E mm	F mm	G mm	H mm	KG
152	6	820	470	550	320	495	67	115	32	43

OPTIONAL Pag. 346



ART. 153

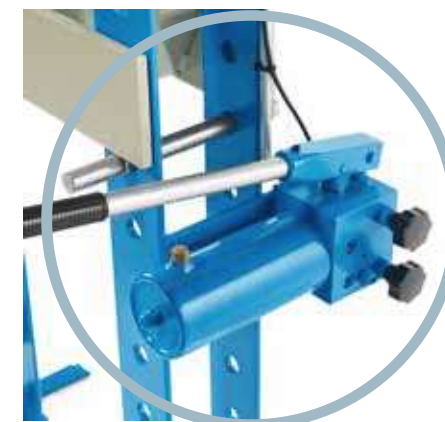
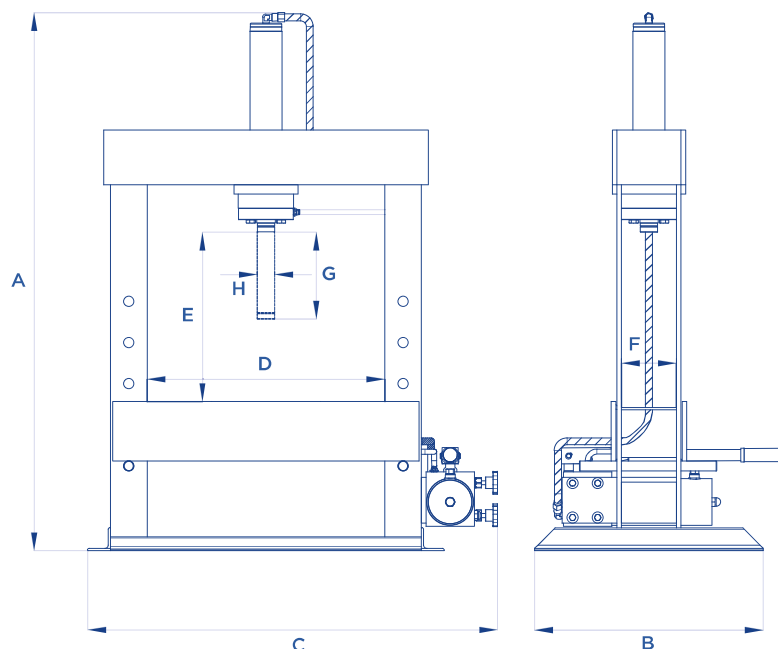

OPTIONAL Pag. 346

ART.	TON	A mm	B mm	C mm	D mm	E mm	F mm	G mm	H mm	KG
153	10	1210	500	895	520	370	120	190	40	104

TRACCIATO TECNICO COSTRUTTIVO

- Compatta struttura in robusto acciaio saldato.
- Stelo del cilindro in acciaio speciale, trattato e cromato.
- Molla in acciaio inserita nel cilindro per un rapido ritorno dello stelo.
- Pompa a mano a due velocità: rapidità in fase di avvicinamento e precisione in fase di lavoro (153).
- Gestione delle due velocità tramite volantino posto sulla pompa (153).
- Pompa a mano ad una velocità (152).
- Massima versatilità grazie al bancale ad altezza regolabile (153).
- Piatto cacciaspina e coppia di prismi a V forniti di serie (153).

TECHNICAL AND STRUCTURAL LAY-OUT

- Compact and sturdy structure fully made of welded steel.
- Shafts made of specially treated and chromium-plated steel.
- Spring made of steel inside the cylinder for a rapid return of the shaft.
- Two-speed manual pump: fast when approaching and precise when working (153).
- Knob on the pump to control both speeds (153).
- One-speed manual pump (152).
- Maximum versatility thanks to the height-adjustable table (153).
- Supplied with a pin-extracting plate and a pair of V-blocks (153).

RELEVÉ TECHNIQUE

- Structure compacte très robuste réalisée exclusivement en acier soudé.
- Tige du cylindre en acier spécial traité et chromé.
- Ressort en acier dans le cylindre pour un retour rapide du vérin.
- Pompe manuelle à deux vitesses: rapidité en phase d'approche et précision en phase de pressage (153).
- Volant à main sur la pompe pour la gestion des deux vitesses (153).
- Pompe manuelle à une vitesse (152).
- Ultra polyvalente grâce au plan de travail réglable en hauteur (153).
- Plateau à trous et couple des prismes à V de série (153).

TECHNISCHE UND KONSTRUKTIVE ANGABEN

- Kompakte Struktur, die aus starkem schweißendem Stahl realisiert ist.
- Zylinderkolben aus speziellen Stahl, behandelt sowie auch verchromt.
- Feder aus Stahl, die in den Zylinder einsteckt, für einen schnellen Rücklauf des Kolbens.
- Zweistufige Handpumpe: Schnelligkeit während die Annäherungsphase und Exaktheit während die Arbeit (153).
- Führung der zwei Geschwindigkeiten dank einen Handrad auf der Pumpe (153).
- Einstufige Handpumpe (152).
- Maximale Vielseitigkeit dank dem höhenverstellbaren Tisch (153).
- Mit einer Auflageplatte und Doppelprismenblöcke (153).

**10•20
TON**



ART. 156



ART. 154/E

PRESSE IDRAULICHE CON POMPA A MANO

HYDRAULIC PRESSES WITH HAND PUMP

PRESSES HYDRAULIQUES AVEC POMPE MANUELLE

HAND-HYDRAULISCHE PRESSEN



OPTIONAL Pag. 346

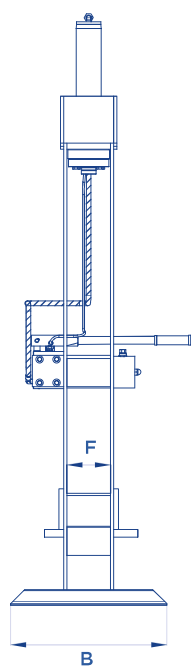
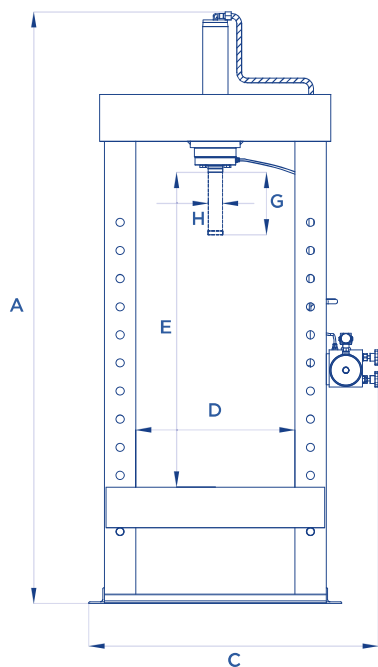

ART.	TON	A  mm	B  mm	C  mm	D  mm	E  mm	F  mm	G  mm	H  mm	 KG
154/E	10	1910	500	870	520	980	120	160	40	94
154	10	1900	500	910	520	980	120	190	40	124
155	15	1930	500	930	510	1020	140	190	40	130
156	20	1960	500	930	510	1020	140	200	50	150

TRACCIATO TECNICO COSTRUTTIVO

- Stelo del cilindro in acciaio speciale, trattato e cromato.
- **Molla in acciaio inserita nel cilindro per un rapido ritorno dello stelo.**
- Pompa a mano a due velocità: rapidità in fase di avvicinamento e precisione in fase di lavoro (154 - 155 - 156).
- Gestione delle due velocità tramite volantino posto sulla pompa (154 - 155 - 156).
- Pompa a mano ad una velocità (154/E).
- Massima versatilità grazie al bancale ad altezza regolabile.
- Piatto cacciaspine e coppia di prismi a V forniti di serie (154 - 155 - 156).

TECHNICAL AND STRUCTURAL LAY-OUT

- Shafts made of specially treated and chromium-plated steel.
- **Spring made of steel inside the cylinder for a rapid return of the shaft.**
- Two-speed manual pump: fast when approaching and precise when working (154 - 155 - 156).
- Knob on the pump to control both speeds (154 - 155 - 156).
- One-speed manual pump (154/E).
- Maximum versatility thanks to the height-adjustable table.
- Supplied with a pin-extracting plate and a pair of V-blocks (154 - 155 - 156).

RELEVÉ TECHNIQUE

- Tige du cylindre en acier spécial traité et chromé.
- **Ressort en acier dans le cylindre pour un rapide retour du tige.**
- Pompe manuelle à deux vitesses : rapidité en phase d'approche et précision en phase de pressage (154 - 155 - 156).
- Volant à main sur la pompe pour la gestion des deux vitesses (154 - 155 - 156).
- Pompe manuelle à une vitesse (154/E).
- Ultra polyvalente grâce au plan de travail réglable en hauteur.
- Plateau à trous et couple des prismes à V de série (154 - 155 - 156).

TECHNISCHE UND KONSTRUKTIVE ANGABEN

- Zylinderkolben aus speziellem Stahl, behandelt sowie auch verchromt.
- **Feder aus Stahl, die in den Zylinder einsteckt ist, für einen schnellen Rücklauf des Kolbens.**
- Zweistufige Handpumpe: Schnelligkeit während die Annäherungsphase und Exaktheit während die Arbeit (154 - 155 - 156).
- Führung der zwei Geschwindigkeiten dank einem Handrad auf der Pumpe (154 - 155 - 156).
- Einstufige Handpumpe (154/E).
- Maximale Vielseitigkeit dank dem höhenverstellbaren Tisch.
- Mit einer Auflageplatte und Doppelpismenblöcke (154 - 155 - 156).

30•100
TON



ART. 158



ART. P30/SA

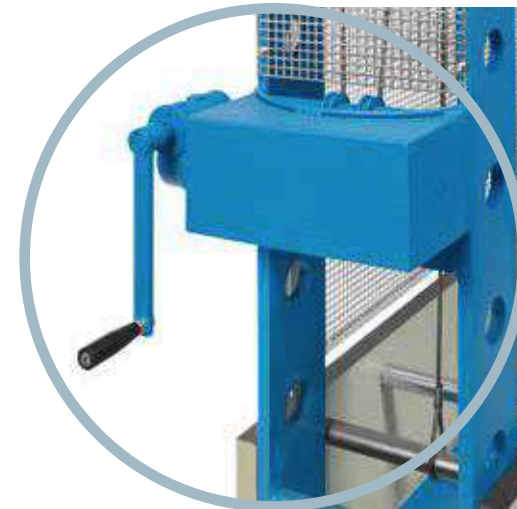

OPTIONAL Pag. 346

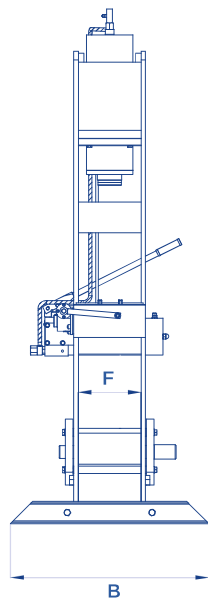
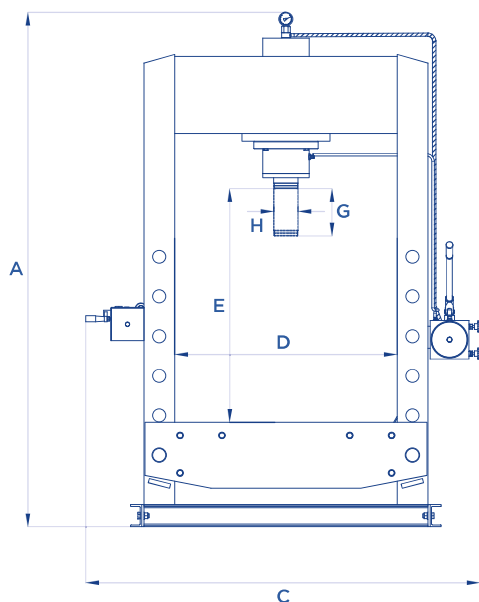

ART.	TON	A \longleftrightarrow mm	B \longleftrightarrow mm	C \longleftrightarrow mm	D \longleftrightarrow mm	E \longleftrightarrow mm	F \longleftrightarrow mm	G \longleftrightarrow mm	H \longleftrightarrow mm	KG 
P30/SA	30	2180	600	1300	695	1000	170	190	60	280
157	40	2260	850	1420	770	1135	200	190	60	405
158	50	2260	850	1420	770	1135	210	190	60	455
159	70	2340	900	1580	880	1120	270	210	90	700
160	100	2440	900	1740	1010	1055	285	215	110	960

TRACCIATO TECNICO COSTRUTTIVO

- Struttura in robusto acciaio saldato.
- Stelo del cilindro in acciaio speciale, trattato e cromato.
- Molla in acciaio inserita nel cilindro per un rapido ritorno dello stelo.
- **Pompa a mano a due velocità: rapidità in fase di avvicinamento e precisione in fase di lavoro.**
- Gestione delle due velocità tramite volantino posto sulla pompa.
- Complete di argano per poter sollevare il bancale in modo pratico e veloce.
- Manometro di grosso diametro fornito di serie.

TECHNICAL AND STRUCTURAL LAY-OUT

- Compact and sturdy structure fully made of welded steel.
- Shafts made of specially treated and chromium-plated steel.
- Spring made of steel inside the cylinder for a rapid return of the shaft.
- **Two-speed manual pump: fast when approaching and precise when working.**
- Knob on the pump to control both speeds.
- Winch to raise easily and quickly the workbench.
- Supplied with a large diameter manometer.

RELEVÉ TECHNIQUE

- Structure compacte très robuste réalisée exclusivement en acier soudé.
- Tige du cylindre en acier spécial traité et chromé.
- Ressort en acier dans le cylindre pour un retour rapide du vérin.
- **Pompe manuelle à deux vitesses : rapidité en phase d'approche et précision en phase de pressage.**
- Volant à main sur la pompe pour la gestion des deux vitesses.
- Treuil pour relever le plan de travail rapidement et sans effort.
- Manomètre de gros diamètre de série.

TECHNISCHE UND KONSTRUKTIVE ANGABEN

- Struktur aus starkem schweißendem Stahl.
- Zylinderkolben aus speziellen Stahl, behandelt sowie auch verchromt.
- Feder aus Stahl, die in den Zylinder einsteckt, für einen schnellen Rücklauf des Kolbens.
- **Zweistufige Handpumpe: Schnelligkeit während die Annäherungsphase und Exaktheit während die Arbeit.**
- Führung der zwei Geschwindigkeiten dank einen Handrad auf der Pumpe.
- Mit einer Winde, um den Tisch einfach und schnell zu heben.
- Mit einem serienmäßigen Manometer mit einem großen Durchmesser.

**10-50
TON**

PRESSE IDRAULICHE CON POMPA IDROPNEUMATICA A PEDALE

HYDRAULIC PRESSES WITH HYDROPNEUMATIC FOOT PUMP

PRESSES HYDRAULIQUES AVEC POMPE HYDROPNEUMATIQUE A PEDALE

HYDRAULISCHE PRESSEN MIT HYDROPNEUMATISCHER FUSSPUMPE



ART. 158/IP



ART. 156/IP

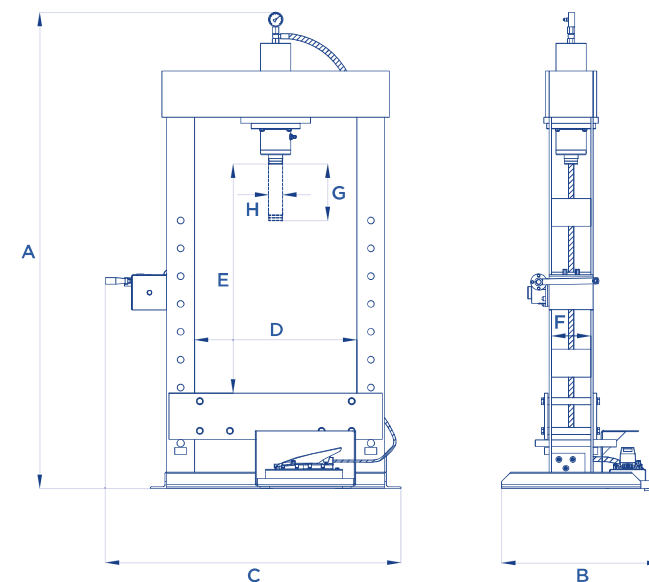

OPTIONAL Pag. 346



ART.	TON		 mm/min	 mm	 mm	 mm	 mm	 mm	 mm	 mm	 mm	 KG
154/IP	10	6-8 bar	450	1910	500	780	520	980	120	190	40	124
155/IP	15	6-8 bar	450	1930	500	790	510	1020	140	190	40	130
156/IP	20	6-8 bar	330	1960	500	810	510	1020	140	200	50	150
P30/SAIP	30	6-10 bar	170	2170	600	1270	695	1000	170	190	60	280
157/IP	40	6-10 bar	170	2260	850	1330	770	1135	200	190	60	405
158/IP	50	6-10 bar	120	2260	850	1330	770	1135	210	190	60	445

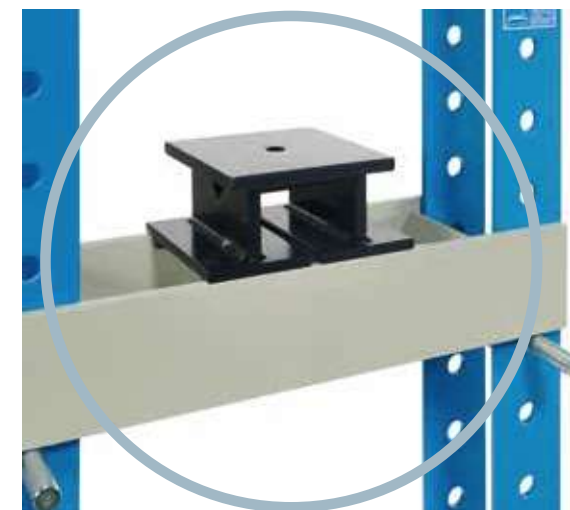

 Velocità stelo • Rod speed • Vitesse du piston • Hub Geschwindigkeit

 Alimentazione pneumatica • Pneumatic feeding • Pression d'alimentation • Benötigter Luftdruck

TRACCIATO TECNICO COSTRUTTIVO

- Stelo del cilindro in acciaio speciale, trattato e cromato.
- Molla in acciaio inserita nel cilindro per un rapido ritorno dello stelo.
- **La pompa idropneumatica a pedale consente di lavorare avendo entrambe le mani libere.**
- Massima versatilità grazie al bancale ad altezza regolabile.
- Complete di argano per poter sollevare il bancale in modo pratico e veloce (P30/SAIP - 157/IP - 158/IP).
- Piatto cacciaspina e coppia di prismi a V forniti di serie (154/IP - 155/IP - 156/IP).
- Manometro di grosso diametro fornito di serie (P30/SAIP - 157/IP - 158/IP).

TECHNICAL AND STRUCTURAL LAY-OUT

- Shafts of the cylinder of treated and chromium-plated special steel.
- Spring of steel inside the cylinder for a rapid return to the shaft.
- **Hydro-pneumatic foot pump that lets you work with both the hands free.**
- Maximum versatility thanks to the height-adjustable table.
- Winch to easily and quickly lift the working-table (P30/SAIP - 157/IP - 158/IP).
- Pin-extracting plate with a couple of V-blocks (154/IP - 155/IP - 156/IP).
- Big-diameter manometer (P30/SAIP - 157/IP - 158/IP).

RELEVÉ TECHNIQUE

- Tige du cylindre en acier spécial traité et chromé.
- Ressort en acier dans le cylindre pour un rapide retour du tige.
- **Pompe hydropneumatique à pédale pour travailler avec toutes les deux mains libres.**
- Ultra polyvalente grâce au plan de travail réglable en hauteur.
- Treuil pour relever le plan de travail rapidement et sans effort (P30/SAIP - 157/IP - 158/IP).
- Plateau à trous et couple des prismes à V de série (154/IP - 155/IP - 156/IP).
- Manomètre de gros diamètre de série (P30/SAIP - 157/IP - 158/IP).

TECHNISCHE UND KONSTRUKTIVE ANGABEN

- Zylinderkolben aus speziellen Stahl, behandelt sowie auch verchromt.
- Feder aus Stahl, die in den Zylinder einsteckt ist, für einen schnellen Rücklauf des Kolbens.
- **Fußhydropneumatische Pumpe, die erlaubt Sie mit den beiden Freihände zu arbeiten.**
- Maximale Vielseitigkeit dank dem höhenverstellbaren Tisch.
- Mit einer Winde, um den Tisch einfach und schnell zu heben (P30/SAIP - 157/IP - 158/IP).
- Mit einer Auflageplatte und Doppelprismenblocke (154/IP - 155/IP - 156/IP).
- Mit einem serienmäßigen Manometer mit einem großen Durchmesser (P30/SAIP - 157/IP - 158/IP).

**10-30
TON**



ART. P30/SAP



ART. 155/P

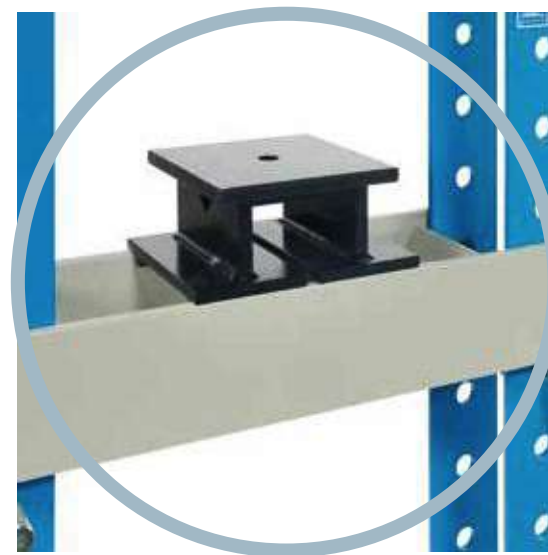

PRESE IDRAULICHE CON POMPA A PEDALE

HYDRAULIC PRESSES WITH FOOT PUMP
PRESSES HYDRAULIQUES AVEC POMPE A PEDALE
HYDRAULISCHE PRESSEN MIT FUSSPUMPE

OPTIONAL Pag. 346

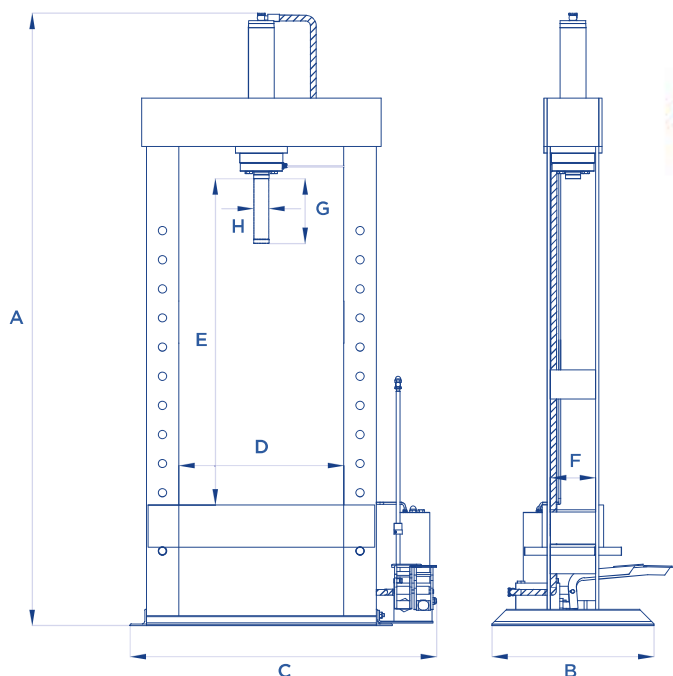

ART.	TON	A mm	B mm	C mm	D mm	E mm	F mm	G mm	H mm	KG
154/P	10	1910	500	910	520	980	120	190	40	124
155/P	15	1930	500	930	510	1020	140	190	40	130
156/P	20	1960	500	930	510	1020	140	200	50	150
P30/SAP	30	2170	600	1300	695	1000	170	190	60	280

TRACCIATO TECNICO COSTRUTTIVO

- Stelo del cilindro in acciaio speciale, trattato e cromato.
- Molla in acciaio inserita nel cilindro per un rapido ritorno dello stelo.
- La pompa a pedale consente di lavorare avendo entrambe le mani libere.
- **Pompa a due velocità: rapidità in fase di avvicinamento e precisione in fase di lavoro.**
- Massima versatilità grazie al bancale ad altezza regolabile.
- Completa di argano per poter sollevare il bancale in modo pratico e veloce (P30/SAP).
- Piatto cacciaspine e coppia di prismi a V forniti di serie (154/P - 155/P - 156/P).
- Manometro di grosso diametro fornito di serie (P30/SAP).

TECHNICAL AND STRUCTURAL LAY-OUT

- Shafts of the cylinder of treated and chromium-plated special steel.
- Spring of steel inside the cylinder for a rapid return to the shaft.
- Foot pump that lets you work with both the hands free.
- **Two-speed pump: rapidity during the approaching phase and precision during the working phases.**
- Maximum versatility thanks to the height-adjustable table.
- Winch to easily and quickly lift the working-table (P30/SAP).
- Pin-extracting plate with a couple of V-blocks (154/P - 155/P - 156/P).
- Big-diameter manometer (P30/SAP).

RELEVÉ TECHNIQUE

- Tige du cylindre en acier spécial traité et chromé.
- Ressort en acier dans le cylindre pour un rapide retour du tige.
- Pompe à pédale pour travailler avec toutes les deux mains libres.
- **Pompe à deux vitesses : rapidité pendant la phase d'approchement et précision pendant le travail.**
- Ultra polyvalente grâce au plan de travail réglable en hauteur
- Treuil pour relever le plan de travail rapidement et sans effort (P30/SAP).
- Plateau à trous et couple des prismes à V de série (154/P - 155/P - 156/P).
- Manomètre de gros diamètre de série (P30/SAP).

TECHNISCHE UND KONSTRUKTIVE ANGABEN

- Zylinderkolben aus speziellen Stahl, behandelt sowie auch verchromt.
- Feder aus Stahl, die in den Zylinder einsteckt, für einen schnellen Rücklauf des Kolbens.
- Fußpumpe, die erlaubt Sie mit den beiden Freihände zu arbeiten.
- **Zweistufige Pumpe: Schnelligkeit während die Annäherungsphase und Exaktheit während die Arbeit.**
- Maximale Vielseitigkeit dank dem höhenverstellbaren Tisch.
- Mit einer Winde, um den Tisch einfach und schnell zu heben (P30/SAP).
- Mit einer Auflageplatte und Doppelprismenblocke (154/P - 155/P - 156/P).
- Mit einem serienmäßigen Manometer mit einem großen Durchmesser (P30/SAP).

**10•100
TON**

**ML
LINE**

PRESSE ELETTROIDRAULICHE

ELECTROHYDRAULIC PRESSES
PRESSES ELECTROHYDRAULIQUES
ELEKTROHYDRAULISCHE PRESSEN



ART. 156/ML

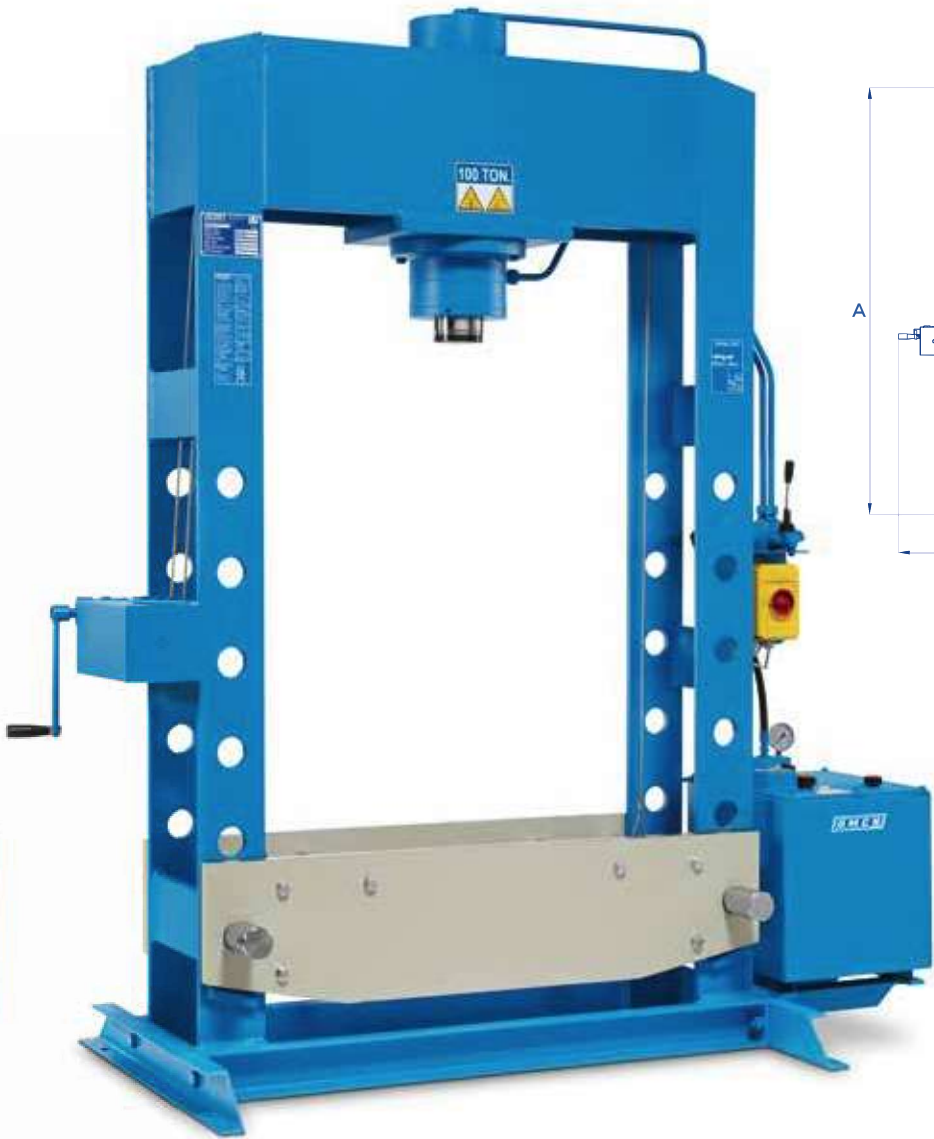

ART. 164

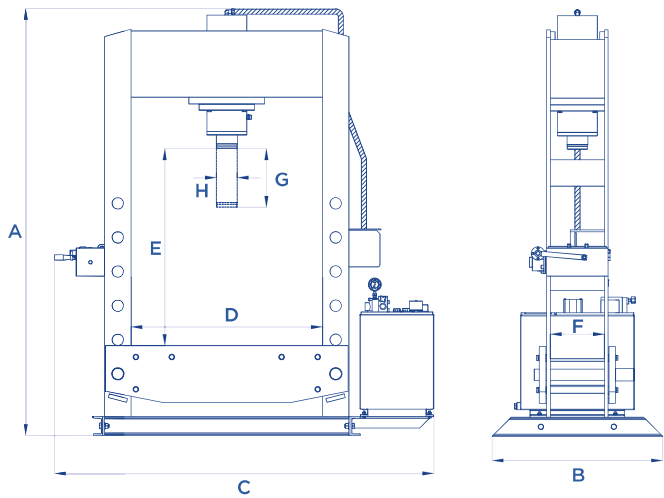

OPTIONAL Pag. 346



ART.	TON	 mm/min	 mm	 mm	 mm	 mm	 mm	 mm	 mm	 mm		 KG
154/ML	10	570	1910	500	1100	520	980	120	260	40	1,5 kw	174
156/ML	20	300	1960	500	1110	510	1000	140	285	50	1,5 kw	190
P30/ML	30	300	2020	600	1600	695	1000	170	260	60	1,5 kw	320
161	40	300	2130	850	1575	770	1135	200	260	60	1,5 kw	440
162	50	210	2130	850	1570	770	1135	210	260	60	1,5 kw	480
163	70	260	2210	900	1755	880	1120	270	310	90	3 kw	740
164	100	180	2310	900	1930	1010	1055	285	310	110	3 kw	1000



Velocità stelo • Rod speed • Vitesse du piston • Hub Geschwindigkeit



Potenza motore • Motor power • Puissance moteur • Motorleistung

TRACCIATO TECNICO COSTRUTTIVO

- Stelo del cilindro in acciaio speciale, trattato e cromato.
- **Centralina motorizzata ad una velocità.**
- Azionamento tramite distributore a leva a 3 posizioni. Questa soluzione permette di avere una mano libera per lavorare.
- Dotate di valvola di taratura per regolare la potenza in base alla lavorazione da eseguire.
- Massima versatilità grazie al bancale ad altezza regolabile.
- Complete di argano per poter sollevare il bancale in modo pratico e veloce (escluso 154/ML - 156/ML).
- Manometro fornito di serie.

TECHNICAL AND STRUCTURAL LAY-OUT

- Shafts of the cylinder made of treated and chromium-plated special steel.
- **Motorized one-speed control unit.**
- Start-up by means of a 3-position lever distributor. This solution allows you to have one hand free to work.
- With a control valve to set the power according to the work you have to do.
- Maximum versatility thanks to the height-adjustable table.
- Winch to easily and quickly lift the working-table (except for art. 154/ML - 156/ML).
- Supplied with a manometer.

RELEVÉ TECHNIQUE

- Tige du cylindre en acier spécial traité et chromé.
- **Groupe hydraulique motorisé à une vitesse.**
- Actionnement par distributeur à levier à 3 positions. Cette solution permet d'avoir une main libre pour travailler.
- Avec soupape de calibrage pour régler la puissance par rapport au travail à faire.
- Ultra polyvalent grâce au plan de travail réglable en hauteur.
- Treuil pour relever le plan de travail rapidement et sans effort (sauf art. 154/ML - 156/ML).
- Manomètre de série.

TECHNISCHE UND KONSTRUKTIVE ANGABEN

- Zylinderkolben aus speziellen Stahl, behandelt sowie auch verchromt.
- **Einstufiges motorisiertes Steuergerät.**
- Antrieb mittels einem Hebel-Dreiwegeverteiler.
- Diese Lösung erlaubt Sie einem Freihand zu haben, um zu arbeiten.
- Mit einem Eichventil, um die Kraft der Maschine gemäß die Arbeitstypologie zu regeln.
- Maximale Vielseitigkeit dank dem höhenverstellbaren Tisch.
- Mit einer Winde, um den Tisch einfach und schnell zu heben (nicht für art. 154/ML - 156/ML).
- Serienmäßiger Manometer.

**20•150
TON**

**W
LINE**



ART. 164/W



ART. P30/W

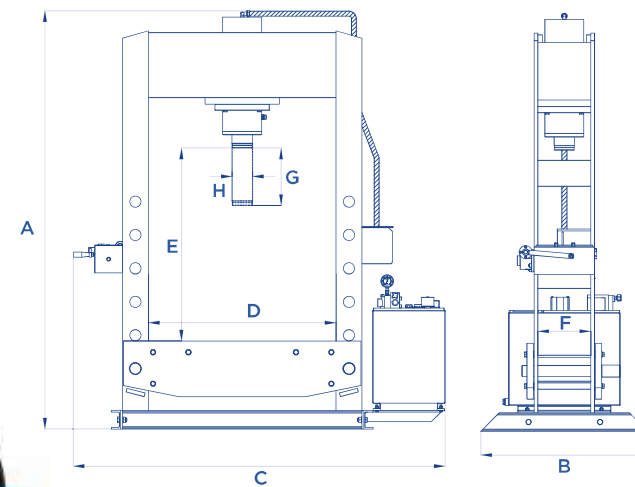



ART.	TON	 mm/min	 mm/min	 mm	 mm	 mm	 mm	 mm	 mm	 mm	 mm		 KG
156/W	20	450		1960	500	1110	510	1000	140	285	50	1,5 kw	200
P30/W	30	575		2020	600	1600	695	1000	170	260	60	3 kw	330
161/W	40	575		2130	850	1650	775	1135	195	260	60	3 kw	470
162/W	50	600	215	2130	850	1650	775	1135	205	260	60	1,5 kw	530
163/W	70	595	260	2210	900	1755	880	1120	265	310	90	3 kw	800
164/W	100	570	180	2310	900	1930	1010	1055	280	310	110	3 kw	1050
164/WS	100	570	180	2470	1300	2320	1520	1065	360	310	110	3 kw	1500
204/W	150	600	120	2600	1300	2470	1520	1018	410	400	140	4 kw	2200
204/WE	150	600	120	2600	1300	1970	1020	1035	410	400	140	4 kw	1870

-  Potenza motore • Motor power • Puissance moteur • Motorleistung  Velocità lavoro • Working speed • Vitesse travail • Arbeitsgeschwindigkeit
-  Velocità avvicinamento • Approaching speed • Vitesse approche • Vorlaufgeschwindigkeit

TRACCIATO TECNICO COSTRUTTIVO

- Stelo del cilindro in acciaio speciale, trattato e cromato.
- Centralina motorizzata a due velocità ad inserimento automatico (escluso 156/W - P30/W - 161/W).
- **Azionamento tramite distributore a leva a 3 posizioni. Questa soluzione permette di avere una mano libera per lavorare.**
- Dotate di valvola di taratura per regolare la potenza in base alla lavorazione da eseguire.
- Massima versatilità grazie al bancale ad altezza regolabile.
- Sollevamento del bancale tramite apposito argano (P30/W - 161/W - 162/W - 163/W - 164/W).
- Sollevamento del bancale tramite asta (164/WS - 204/W - 204/WE).
- Manometro fornito di serie.

TECHNICAL AND STRUCTURAL LAY-OUT

- Shaft of the cylinder made of treated and chromium-plated special steel.
- Motorized 2-speeds control unit with automatic insertion (except art. 156/W - P30/W - 161/W).
- **Start-up by means of a 3-position lever distributor. This solution allows you to have one hand free to work.**
- With a control valve to set the power according to the work you have to do.
- Maximum versatility thanks to the height-adjustable table.
- Winch to raise easily and quickly the workbench (P30/W - 161/W - 162/W - 163/W - 164/W).
- Rod to raise the workbench (164/WS - 204/W - 204/WE).
- Supplied with a manometer.

RELEVÉ TECHNIQUE

- Tige du cylindre en acier spécial traité et chromé.
- Groupe hydraulique motorisé à deux vitesses à insertion automatique (sauf pour les art. 156/W - P30/W - 161/W).
- **Actionnement par distributeur à levier à 3 positions. Cette solution permet d'avoir une main libre pour travailler.**
- Soupape de calibrage pour régler la puissance par rapport au travail à faire.
- Ultra polyvalente grâce au plan de travail réglable en hauteur.
- Relevage du plan de travail par treuil (P30/W - 161/W - 162/W - 163/W - 164/W).
- Relevage du plan de travail par barre (164/WS - 204/W - 204/WE).
- Manomètre de série.

TECHNISCHE UND KONSTRUKTIVE ANGABEN

- Zylinderkolben aus speziellen Stahl, behandelt sowie auch verchromt.
- Zweistufiges motorisiertes Steuergerät mit automatischen Einstecken (nicht für Art. 156/W - P30/W - 161/W).
- **Antrieb mittels einem Hebel-Dreivegeverteiler. Diese Lösung erlaubt Sie einem Freihand zu haben, um zu arbeiten.**
- Mit einem Eichventil, um die Kraft der gemäß die Arbeitstypologie zu regeln.
- Maximale Vielseitigkeit dank dem höhenverstellbaren Tisch.
- Hebung dem Tisch mittels einer Winde (P30/W - 161/W - 162/W - 163/W - 164/W).
- Hebung dem Tisch mittels einer Stange (164/WS - 204/W - 204/WE).
- Serienmäßiger Manometer.

**10•150
TON**

**R
LINE**

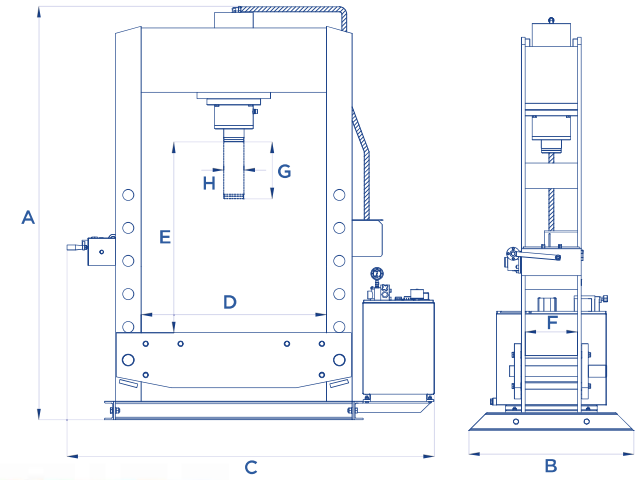
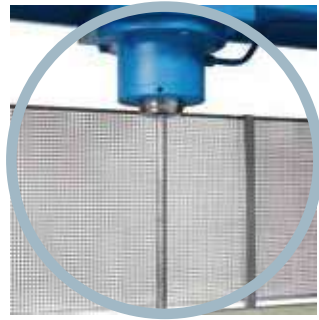
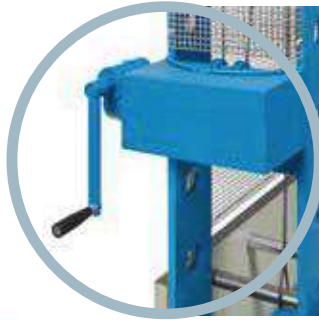













ART. 204/R



ART. 164/R



ART.	TON	 mm/min	CE	 mm/min	 A mm	 B mm	 C mm	 D mm	 E mm	 F mm	 G mm	 H mm		
154/MR	10	5300	1750	350	1910	500	1100	520	980	120	260	40	0,75 kw	194
156/MR	20	5200	1100	300	1960	500	1110	510	1000	140	285	50	0,75 kw	208
P30/MR	30	4490	1550	300	2020	600	1600	695	1000	170	260	60	1,5 kw	338
161/R	40	4490	1530	300	2130	850	1650	775	1135	195	260	60	1,5 kw	530
162/R	50	3100	1540	210	2130	850	1650	775	1135	205	260	60	1,5 kw	560
163/R	70	3400	1600	260	2210	900	1755	880	1120	265	310	90	3 kw	850
164/R	100	2360	1600	180	2310	900	1930	1010	1055	280	310	110	3 kw	1100
164/RS	100	2360	1600	180	2470	1300	2320	1520	1065	360	310	110	3 kw	1500
204/R	150	1600		120	2600	1300	2470	1520	1018	410	400	140	4 kw	2200
204/RE	150	1600		120	2600	1300	1970	1020	1035	410	400	140	4 kw	1870

 Potenza motore • Motor power • Puissance moteur • Motorleistung  Velocità lavoro • Working speed • Vitesse travail • Arbeitsgeschwindigkeit

 Velocità avvicinamento • Approaching speed • Vitesse approche • Vorlaufgeschwindigkeit

TRACCIATO TECNICO COSTRUTTIVO

- Stelo del cilindro in acciaio speciale, trattato e cromato.
- Centralina motorizzata a due velocità ad inserimento automatico.
- **Funzionamento tramite distributore a leva e pulsante sul quadro da azionare contemporaneamente.**
- Complete di pannelli protettivi posteriore e laterali in acciaio zincato.
- Dotate di valvola di taratura per regolare la potenza in base alla lavorazione da eseguire.
- Massima versatilità grazie al bancale ad altezza regolabile.
- Sollevamento del bancale tramite apposito argano (P30/MR - 161/R - 162/R - 163/R - 164/R).
- Sollevamento del bancale tramite asta (164/RS - 204/R - 204/RE).
- Manometro fornito di serie.

TECHNICAL AND STRUCTURAL LAY-OUT

- Shaft of the cylinder made of treated and chromium-plated special steel.
- Motorized 2-speeds control unit with automatic insertion.
- **Operated by lever distributor and button on the control box to be activated simultaneously.**
- Protection rear and side panels made of zinc-plated steel.
- Calibrating valve to control the power according to the work you have to do.
- Maximum versatility thanks to the height-adjustable table.
- Winch to raise workbench (P30/MR - 161/R - 162/R - 163/R - 164/R).
- Shaft to raise workbench (164/RS - 204/R - 204/RE).
- Supplied with standard manometer.

RELEVÉ TECHNIQUE

- Tige du cylindre en acier spécial traité et chromé.
- Groupe hydraulique de commande motorisé à deux vitesses à insertion automatique.
- **Fonctionnement par distributeur à levier et bouton sur le boîtier électrique à activer en simultanée.**
- Panneaux de protection arrière et sur les côtés en acier galvanisé.
- Soupape de calibrage pour régler la puissance par rapport au travail à faire.
- Ultra polyvalence grâce au plan de travail réglable en hauteur.
- Relevage du plan de travail par treuil (P30/MR - 161/R - 162/R - 163/R - 164/R).
- Relevage du plan de travail par barre (164/RS - 204/R - 204/RE).
- Manomètre de série.

TECHNISCHE UND KONSTRUKTIVE ANGABEN

- Zylinderkolben aus speziellen Stahl, behandelt sowie auch verchromt.
- Zweistufiges motorisiertes Steuergerät mit automatischen Einstecken.
- **Betrieb mittels einem Hebelverteiler und einem Druckknopf auf die Schaltkaste, die gleichzeitig geschaltet sein müssen.**
- Mit hinter- und seitlich Schutztafel aus verzinktem Stahl.
- Mit einem Eichventil, um die Kraft der Maschine gemäß die Arbeitstypologie zu regeln.
- Maximale Vielseitigkeit dank dem höhenverstellbaren Tisch.
- Hebung dem Tisch mittels einer Winde (P30/MR - 161/R - 162/R - 163/R - 164/R).
- Hebung dem Tisch mittels einer Stange (164/RS - 204/R - 204/RE).
- Serienmäßiger Manometer.

**200•300
TON**

**HEAVY
DUTY**

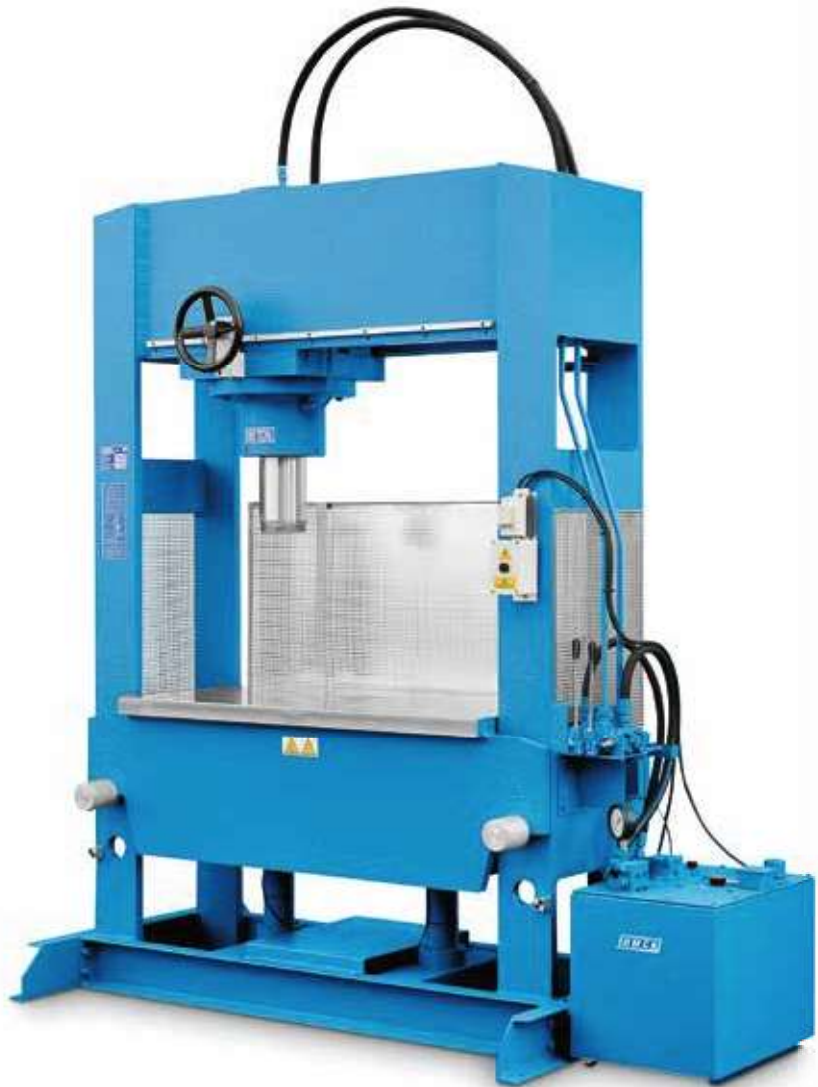

ART. 205/R+022/C

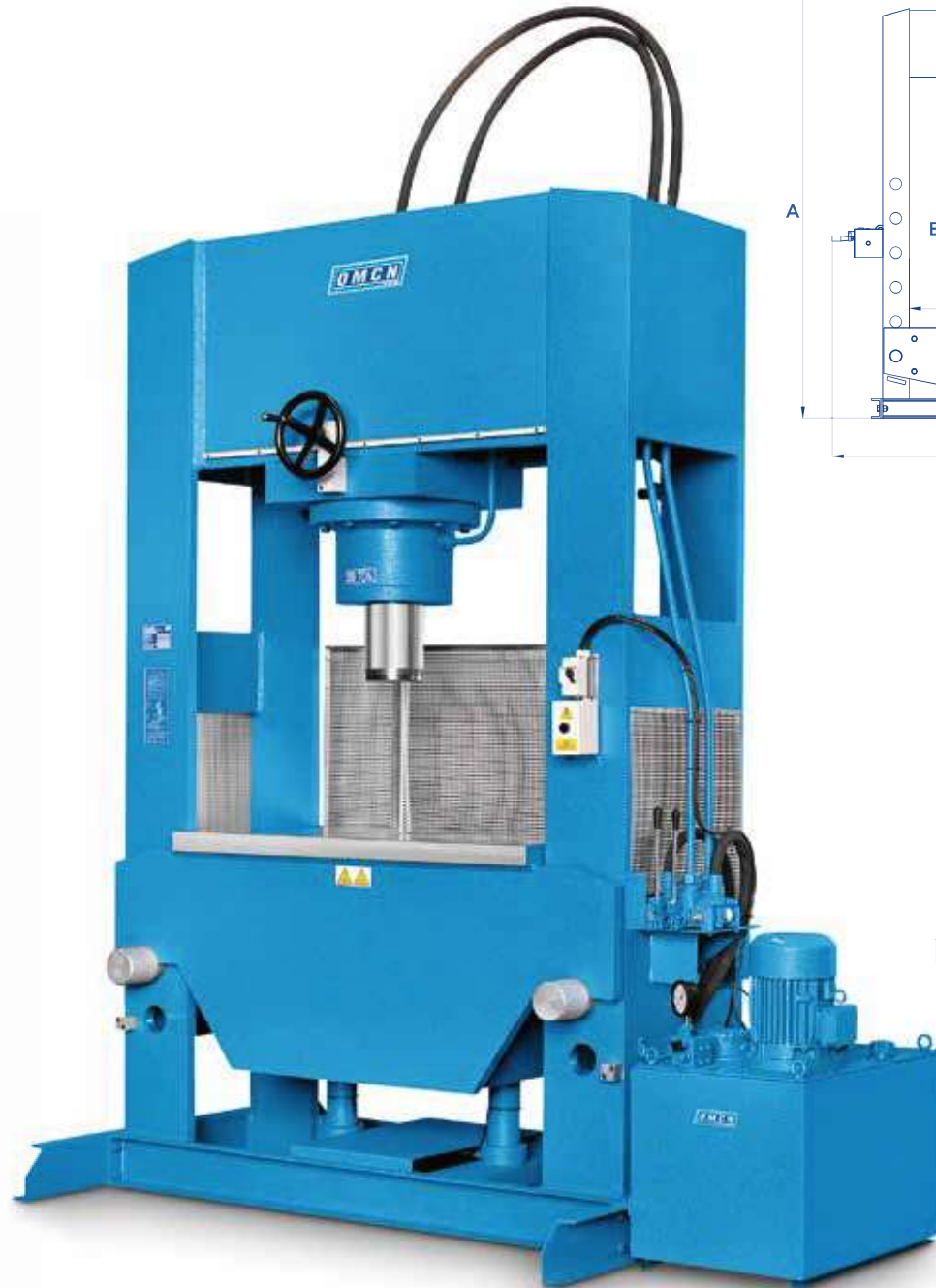

ART. 280/R+022/D

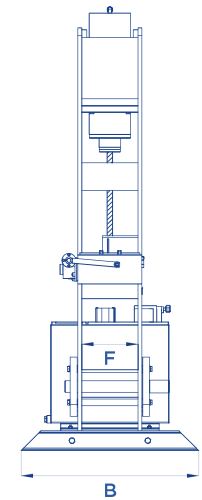
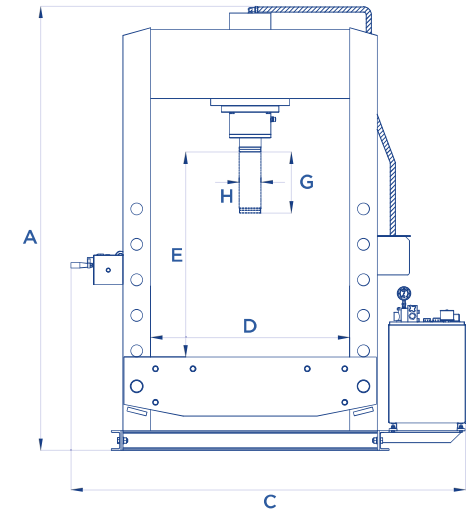

OPTIONAL Pag. 346

ART.	TON	 mm/min	 mm/min	 mm	 mm	 mm	 mm	 mm	 mm	 mm	 mm		
205/R	200	1300	95	2995	1310	2600	1520	1020	520	520	170	4 kw	4150
205/W	200	600	95	2995	1310	2600	1520	1020	520	520	170	4 kw	4150
280/R	300	1000	95	3415	1700	2900	1500	960	640	500	210	5,5 kw	8200
280/W	300	600	95	3415	1700	2900	1500	960	640	500	210	5,5 kw	8200

-  Potenza motore • Motor power • Puissance moteur • Motorleistung
-  Velocità lavoro • Working speed • Vitesse travail • Arbeitsgeschwindigkeit
-  Velocità avvicinamento • Approaching speed • Vitesse approche • Vorlaufgeschwindigkeit

TRACCIATO TECNICO COSTRUTTIVO

- Stelo del cilindro in acciaio speciale, trattato e cromato.
- Centralina motorizzata a due velocità ad inserimento automatico.
- Funzionamento tramite distributore a leva e pulsante sul quadro da azionare contemporaneamente (205/R - 280/R).
- Azionamento tramite distributore a leva a 3 posizioni. Questa soluzione permette di avere una mano libera per lavorare (205/W - 280/W).
- Complete di pannelli protettivi posteriore e laterali in acciaio zincato (205/R - 280/R).
- Dotate di valvola di taratura per regolare la potenza in base alla lavorazione da eseguire.
- **Sollevamento del bancale tramite due cilindri idraulici azionabili tramite apposita leva.**
- Complete di piano di lavoro fresato.

TECHNICAL AND STRUCTURAL LAY-OUT

- Shafts of treated and chromium-plated special steel.
- Motorized 2-speeds control unit with automatic insertion.
- Operation by lever distributor and a button on the control box to be activated simultaneously (205/R - 280/R).
- Start-up by means of a 3-position lever distributor. This solution allows you to have one hand free to work (205/W - 280/W).
- Protection rear and lateral panels made of zinc-plated steel (205/R - 280/R).
- Calibrating valve to set the power according to the work you have to do.
- **Two hydraulic cylinders operated by a lever to raise the workbench.**
- Supplied with a milled working-table.

RELEVÉ TECHNIQUE

- Tige du cylindre en acier spécial traité et chromé.
- Groupe hydraulique motorisé à deux vitesses à insertion automatique.
- Fonctionnement par distributeur à levier et bouton sur le cadre à activer en simultanée (205/R - 280/R).
- Actionnement par distributeur à levier à 3 positions. Cette solution permet d'avoir une main libre pendant le travail (205/W - 280/W).
- Panneaux de protection arrière et sur les côtés en acier galvanisé (205/R - 280/R).
- Soupape de calibrage pour régler la puissance par rapport au travail à faire.
- **Relevage du plan de travail au moyen de deux vérins hydrauliques actionnés par levier.**
- Livré avec un plateau fraisé.

TECHNISCHE UND KONSTRUKTIVE ANGABEN

- Zylinderkolben aus speziellen Stahl, behandelt sowie auch verchromt.
- Zweistufiges motorisiertes Steuergerät mit automatischen Einstecken.
- Betrieb mittels einem Hebelverteiler und einem Druckknopf auf die Schaltkaste, die gleichzeitig geschaltet sein müssen (205/R - 280/R).
- Antrieb mittels einem Hebel-Dreiwegeverteiler.
- Diese Lösung erlaubt Sie einem Freihand zu haben, um zu arbeiten (205/W - 280/W).
- Mit hinter- und seitlich Schutztafel aus verzinktem Stahl (205/R - 280/R).
- Mit einem Eichventil, um die Kraft der Maschine gemäß die Arbeitstypologie zu regeln.
- **Hebung dem Tisch mittels zwei hydraulischer Zylindern, die mittels des geeigneten Hebels schaltbar sind.**
- Mit einem gefrästem Tisch

**100•150
TON**

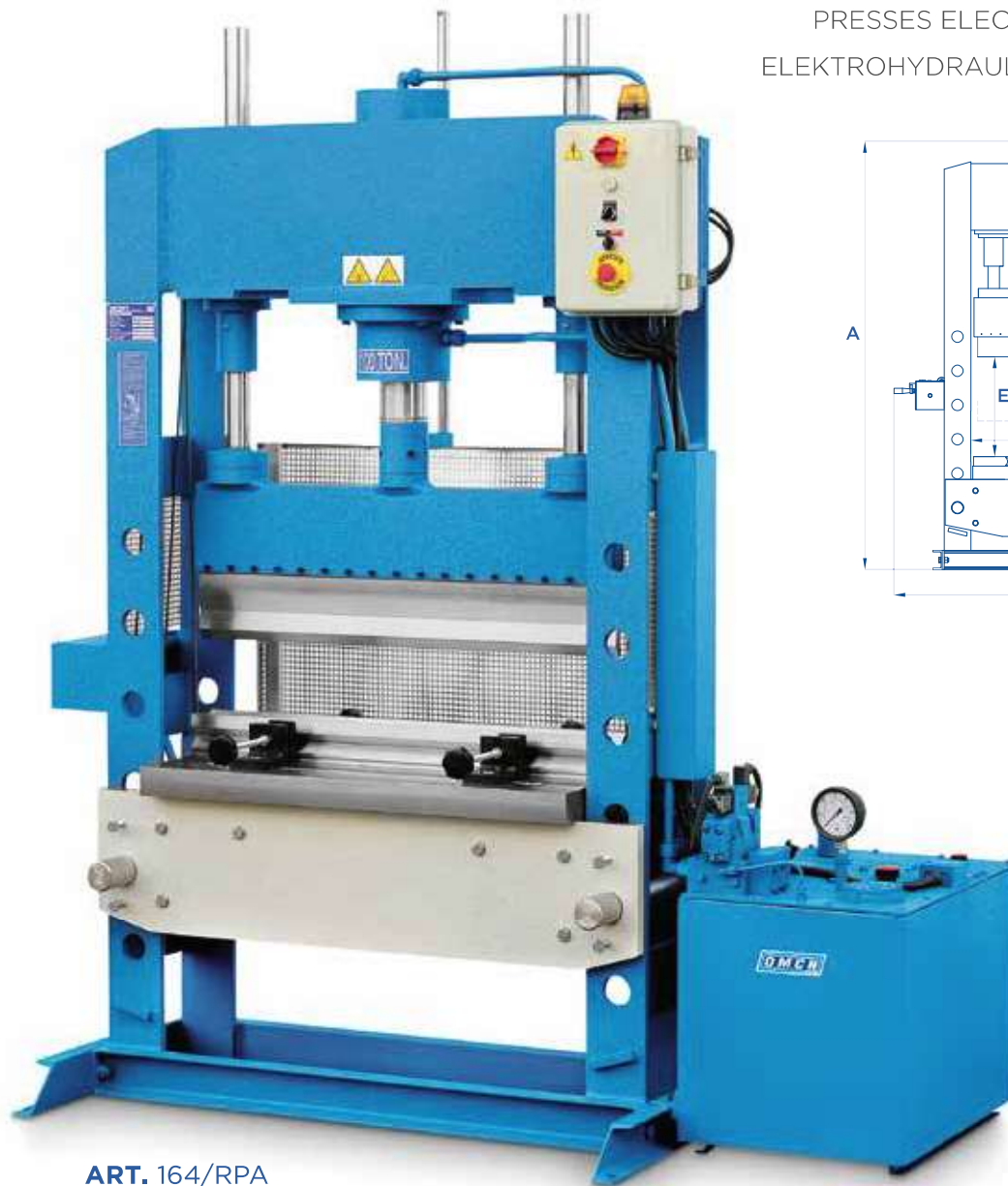
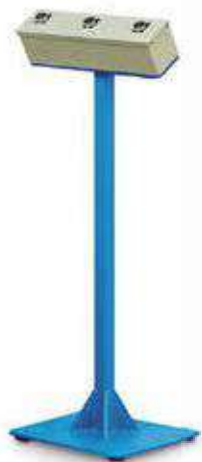
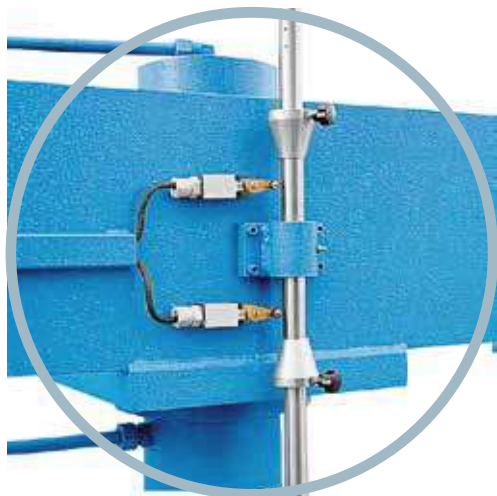



ART. 164/RPA

PRESSE ELETTRIDRAULICHE PER PIEGATURE

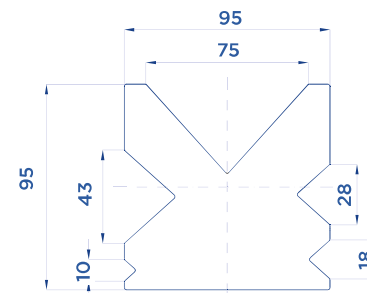
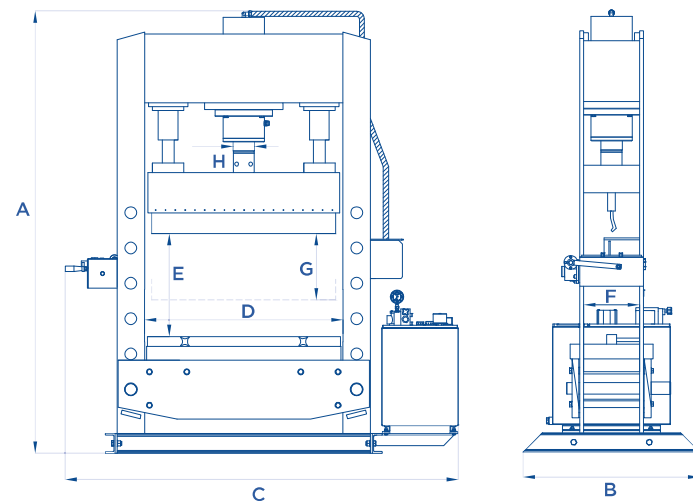
ELECTROHYDRAULIC PRESSES FOR BENDING
PRESSES ELECTROHYDRAULIQUES POUR PLIAGE
ELEKTROHYDRAULISCHE PRESSEN FÜR BLECHBIEGE



ART.	TON	 mm/min	 mm/min	 mm	 mm	 mm	 mm	 mm	 mm	 mm	 mm			
164/RP	100	2360	1600	180	2260	900	1950	1050	400	280	310	110	3 kw	1700
164/RPA	100	2360	1600	180	2300	900	1950	1050	400	280	300	110	3 kw	1900
204/RP	150	1600		120	2500	1300	2530	1500	400	410	400	140	4 kw	3100
204/RPA	150	1600		120	2850	1200	2550	1500	400	410	400	140	4 kw	3100

 Potenza motore • Motor power • Puissance moteur • Motorleistung  Velocità lavoro • Working speed • Vitesse travail • Arbeitsgeschwindigkeit

 Velocità avvicinamento • Approaching speed • Vitesse approche • Vorlaufgeschwindigkeit

TRACCIATO TECNICO COSTRUTTIVO

- Stelo del cilindro in acciaio speciale, trattato e cromato.
- Lama in acciaio ad altissima resistenza.
- **Dotate di una particolare matrice che ospita 5 differenti impronte. Cinque accessori in uno.**
- Dispositivo elettrico di finecorsa.
- Centralina motorizzata a due velocità ad inserimento automatico.
- Funzionamento tramite distributore a leva e pulsante sul quadro da azionare contemporaneamente (164/RP - 204/RP).
- Funzionamento tramite pulsantiera di comando a due mani che consente manovre automatiche condizionate dal dispositivo di finecorsa (164/RPA - 204/RPA).
- Complete di pannelli protettivi posteriore e laterali in acciaio zincato.
- Dotate di valvola di taratura per regolare la potenza in base alla lavorazione da eseguire.
- Per lastre fino a 10 mm. di spessore a mt. 1 di larghezza.

TECHNICAL AND STRUCTURAL LAY-OUT

- Shafts of treated and chromium-plated special steel.
- Blade made of high resistance steel.
- **Supplied with a special forming-die housing 5 different forms. 5 accessories in 1.**
- Electric limit switch device.
- Motorized 2-speeds control unit with automatic insertion.
- Operated by a lever distributor and a button on the control box to be activated simultaneously (164/RP - 204/RP).
- Operated by a two-hand pushbutton board to control automatic operations conditionally to the limit switch device (164/RPA - 204/RPA).
- Protection rear and lateral panels made of zinc-plated steel.
- Calibrating valve to control the power according to the work you have to do.
- For press-bending plates up to 10 mm. thick and 1 mt. wide.

RELEVÉ TECHNIQUE

- Tige du cylindre en acier spécial traité et chromé.
- lame en acier haute résistance.
- **Livré avec une matrice spéciale qui comprend 5 moules différents. 5 accessoires en un.**
- Dispositif électrique de fin de course.
- Groupe hydraulique motorisé à deux vitesses à insertion automatique.
- Fonctionnement par distributeur à levier et bouton sur le boîtier à activer en simultanée (164/RP - 204/RP).
- Pupitre à boutons poussoir pour les manœuvres automatiques contrôlées par le dispositif de fin de course (164/RPA - 204/RPA).
- Panneaux de protection arrières et sur les côtés en acier galvanisé.
- Soupape de calibrage pour régler la puissance en fonction du travail à faire.
- Pour tôle jusqu'à 10 mm. d'épaisseur et 1 mt. de largeur.

TECHNISCHE UND KONSTRUKTIVE ANGABEN

- Zylinderkolben aus speziellen Stahl, behandelt sowie auch verchromt.
- Messer aus sehr haltbaren Stahl.
- **Mit eine spezielle Matrice, um 5 besondere Biegeformen zu unterstellen. 5 Zubehöre in nur 1.**
- **Elektroendschalter.**
- Zweistufiges motorisiertes Steuergerät mit automatischen Einstecken.
- Betrieb mittels einem Hebelverteiler und einem Druckknopf auf die Schaltkaste, die gleichzeitig geschaltet sein müssen (164/RP - 204/RP).
- Betrieb mittels einem Zweihand-Schalttafel, wodurch automatische Bedienung möglich sind, die vom Endschalter beeinflusst werden (164/RPA - 204/RPA).
- Mit hinter- und seitlich Schutztafel aus verzinktem Stahl.
- Mit einem Eichventil, um die Kraft der Maschine gemäß die Arbeitstypologie zu regeln.
- Für Blechplatten bis zu 10 mm. Stärke und 1 m Breite.

50•150
TON

**PRESE ELETTRIDRAULICHE
A MONTANTE MOBILE**

ELECTROHYDRAULIC PRESSES WITH MOVABLE STANCHION

PRESSES ELECTROHYDRAULIQUES A MONTANT MOBILE

ELEKTROHYDRAULISCHE PRESSEN MIT BEWEGLICHEM STÄNDER

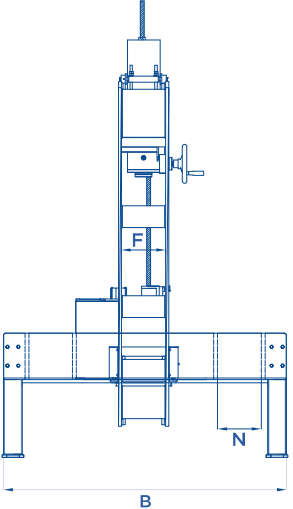
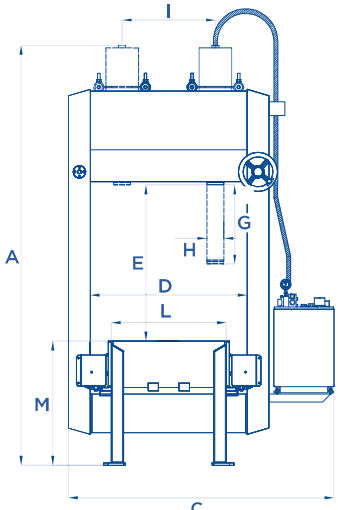

ART. 164/WM

⚙️ Potenza motore • Motor power • Puissance moteur • Motorleistung

⌚ 344 ⚙️ Velocità avvicinamento • Approaching speed • Vitesse approche • Vorlaufgeschwindigkeit

⌚ Velocità lavoro • Working speed • Vitesse travail • Arbeitsgeschwindigkeit

TRACCIATO TECNICO COSTRUTTIVO

- Presse dotate di montante e cilindro traslabili manualmente.
- Ideale per svariati utilizzi quali montaggi, raddrizzature, piegature ed estrazioni.
- Scorrimento del montante su rulli in acciaio pieno completi di cuscinetti.
- Stelo del cilindro in acciaio speciale, trattato e cromato.
- Set di due prolunghe per aumentare la corsa utile dello stelo (accessorio).
- Set di prismi componibili in base al tipo di lavorazione da eseguire (accessorio).
- Centralina motorizzata a due velocità ad inserimento automatico.
- **Azionamento tramite distributore a leva a 3 posizioni. Questa soluzione permette di avere una mano libera per lavorare.**
- Dotate di valvola di taratura per regolare la potenza in base alla lavorazione da eseguire.
- Manometro fornito di serie.

TECHNICAL AND STRUCTURAL LAY-OUT

- Stanchion and cylinder manually movable.
- Perfect for different uses like mounting, straightening, folding and extracting.
- Stanchion move on full steel rollers with bearings.
- Shafts of treated and chromium-plated special steel.
- Set of two extensions to increase the shaft's stroke (optional).
- Set of modular V-blocks according to the kind of work you have to do (optional).
- Motorized 2-speeds control unit with automatic insertion.
- **Start-up by 3-position lever distributor. This solution allows you to have one hand free to work.**
- Calibrating valve to control the power according to the work you have to do.
- Supplied with a manometer.

RELEVÉ TECHNIQUE

- Presses à montants et vérins mobiles.
- Manœuvrables à la main.
- Idéale pour de multiples utilisations: montage, redressage, pliage et extraction.
- Les montants se déplacent sur galets en acier plein sur roulements.
- Tige du vérin en acier spécial traité et chromé.
- Jeu de deux rallonges pour augmenter la course utile du vérin (en option).
- Jeu de prismes modulaires en fonction du travail à faire (en option).
- Groupe hydraulique motorisé à deux vitesses à insertion automatique.
- **Actionnement par distributeur à levier à 3 positions. Cette solution permet d'avoir une main libre pour travailler.**
- Soupape de calibrage pour régler la puissance en fonction du travail à faire.
- Manomètre de série.

TECHNISCHE UND KONSTRUKTIVE ANGABEN

- Pressen mit Manuell schwenkbaren Ständer und Zylinder.
- Für verschiedenartige Benutzungen, wie Montagen, Richten, Verbiegungen und Ausziehungen geeignet.
- Der Ständer gleitet auf Vollstahlrollen mit Lager.
- Zylinderkolben aus speziellen Stahl, behandelt sowie auch verchromt.
- Satz von Verlängerungen, um den Kolbenhub zu vergrößern (zusätzlich).
- Satz von zusammensetzbare Prismenblöcken gemäß die Arbeitstypologie (zusätzlich).
- Zweistufiges motorisiertes Steuergerät mit automatischen Einstecken.
- Antrieb mittels einem Hebel-Dreiwegeverteiler.
- **Diese Lösung erlaubt Sie einem Freihand zu haben, um zu arbeiten.**
- Mit einem Eichventil, um die Kraft der Maschine gemäß die Arbeitstypologie zu regeln.
- Serienmäßiger Manometer.

ART.	TON	 mm/min	 mm/min	 mm	 mm	 mm	 mm	 mm	 mm	 mm	 mm	 mm	 mm	 mm	 mm	
162/WM	50	600	215	2450	1600	1600	890	810	235	500	60	590	710	800	280	1,5 kw
164/WM	100	570	180	2700	1820	1750	1010	1000	285	500	110	600	740	800	280	3 kw
204/WM	150	590	120	2900	2000	1950	1210	1000	360	500	140	750	1010	900	380	4 kw

ACCESSORI EXTRA DOTAZIONE

EXTRA EQUIPMENT • ACCESSOIRES EN OPTION • EXTRA ZUBEHÖR

SET DI PROLUNGHE

Pair of extensions
Paire de rallonges
2 Verlängerungen

ART.	 mm	Compatibilità Compatibility Kompatibilität
040	150	ART. 162/WM
040/A	250	ART. 164/WM
040/B	250	ART. 204/WM



SET DI PRISMI componibili

Set of modular blocks
Jeu de 4 prismes modulables
Zusammensetzbare Prismenblöcke

- ART. 038 ✓ ART. 162/WM
- ART. 038/A ✓ ART. 164/WM
- ART. 038/B ✓ ART. 204/WM



ACCESSORI EXTRA DOTAZIONE

EXTRA EQUIPMENT • ACCESSOIRES EN OPTION • EXTRA ZUBEHÖR

PRISMI A V

V Blocks
Prismes à V
Prismenblöcke

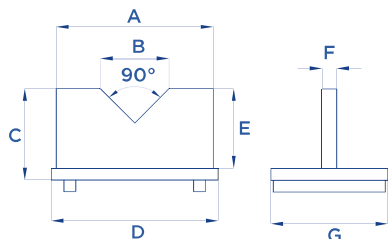

ART.	Compatibilità Compatibility Compatibilité Kompatibilität	A mm	B mm	C mm	D mm	E mm	F mm	G mm	KG
030	SERIE 10 TON	160	70	95	170	80	15	120	4
031	SERIE 15 - 20 TON	160	70	95	190	80	15	120	8
031/A	SERIE 30 TON	190	80	125	240	100	25	100	9
031/B	SERIE 40 TON	250	100	145	300	120	25	100	12
032	SERIE 50 TON	250	100	145	320	120	25	100	13
032/A	SERIE 50 TON + ART. 022	330	100	180	380	150	30	100	20
033	SERIE 70 TON	330	100	180	380	150	30	100	20
034	SERIE 100 TON (D = 1000 mm)	330	100	180	410	150	30	100	20
034/A	SERIE 100 TON + ART. 022/A SERIE 100 TON (D = 1500 mm)	330	100	190	480	150	30	120	32
035	SERIE 150 TON	450	100	220	560	180	40	120	58
036	SERIE 200 TON	450	100	220	880	180	40	120	60
037	SERIE 300 TON	450	100	220	1000	200	80	150	116



MANOMETRO

Manometers
Manomètres
Manometer

ART. 001 Ø 100 mm

✓ ART. 153 • 154/E • 154 • 155
156 • 154/P • 155/P • 156/P



ART. 002 Ø 63 mm

✓ ART. 152

ART. 002/A Ø 100 mm

✓ ART. 154/IP • 155/IP • 156/IP

PIATTO CACCIASPINE

Pin-extracting plate
Plateaux à trous
Auflageplatte

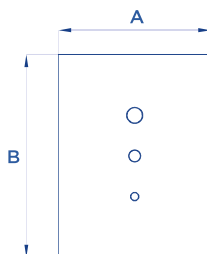
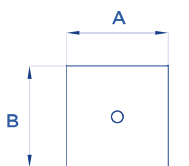

ART.	Compatibilità Compatibility Compatibilité Kompatibilität	A mm	B mm	Diametro Diameter Diamètre Durchmesser	KG
010	SERIE 10 TON	200	200	22 mm	5
011	SERIE 15 - 20 TON	200	200	22 mm	5
011/A	SERIE 30 TON	240	400	15 - 22 - 28 mm	23
012	SERIE 40 - 50 TON	300	400	15 - 22 - 28 mm	28
012/A	SERIE 50 TON + ART. 022	400	400	15 - 22 - 28 mm	50
013	SERIE 70 TON	400	400	15 - 22 - 28 mm	50
014	SERIE 100 TON (D = 1000 mm)	400	400	15 - 22 - 28 mm	63
014/A	SERIE 100 TON + ART. 022/A SERIE 100 TON (D = 1500 mm)	480	480	20 - 30 - 40 mm	90
015	SERIE 150 TON	550	550	20 - 30 - 40 mm	118

D = Luce pressa • Width between uprights • Distance entre les montants • Licht Breite

ACCESSORI EXTRA DOTAZIONE

EXTRA EQUIPMENT • ACCESSOIRES EN OPTION • EXTRA ZUBEHÖR

CONTROPUNTE REGISTRABILI

Pair of adjustable centers

Paire de contrepointes réglables

Zentriervorrichtung



ART. 051

ART. 050 ✓ SERIE 10 - 15 - 20 TON

ART. 051 ✓ SERIE 30 - 40 - 50 - 70 - 100 TON

ART. 052 ✓ SERIE 150 TON (D = 1000 mm)

ART. 053 ✓ SERIE 100 - 150 TON (D = 1500 mm)

PIASTRA FRESATA CON CAVE A T

Tee slots milled plate

Plaque fraisée avec carrières à T

Auflageplatte mit Nuten als Pressformenhalterung

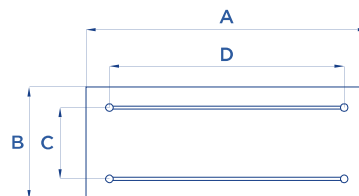

ART.	Compatibilità Compatibility Compatibilité Kompatibilität	A mm	B mm	C mm	D mm	KG
080	SERIE 40 - 50 TON	750	400	160	600	100
081	SERIE 70 TON	850	450	270	700	170
082	SERIE 100 TON (D = 1000 mm)	990	500	300	800	220
083	SERIE 150 TON (D = 1000 mm)	1000	600	380	800	320
084	SERIE 100 - 150 TON (D = 1500 mm)	1500	600	380	1250	480

DISPOSITIVO ELETTRICO DI FINE CORSA

Stop electric device

Dispositif électrique de fin de course

Elektroendschalter



ART. 060 ✓ SERIE 40 - 50 - 70 - 100 TON

ART. 061 ✓ SERIE 150 - 200 TON

ART. 062 ✓ SERIE 300 TON

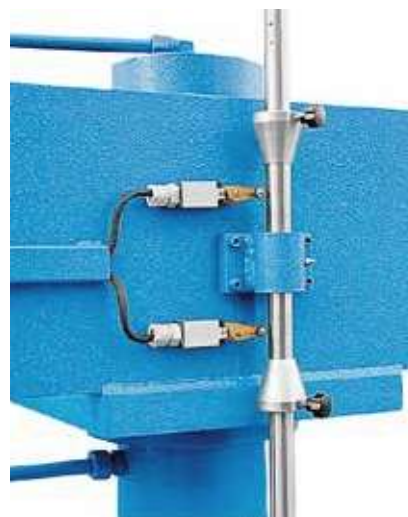

DISPOSITIVO ANTIROTAZIONE STELO

Anti-rotation device of piston rod

Dispositif anti-rotation de la tige

Rotations-Stoppeinrichtung



ART. 070 ✓ SERIE 40 - 50 TON

ART. 071 ✓ SERIE 70 - 100 TON

ART. 072 ✓ SERIE 150 - 200 TON

ART. 073 ✓ SERIE 300 TON

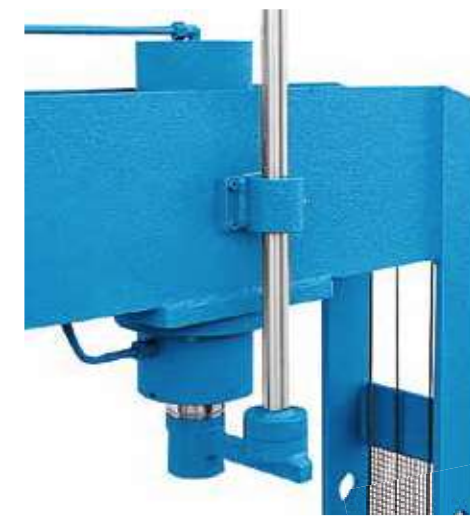

ACCESSORI EXTRA DOTAZIONE

EXTRA EQUIPMENT • ACCESSOIRES EN OPTION • EXTRA ZUBEHÖR

CILINDRO MOBILE

Mobile ram
Piston mobile
Versetzbarem Zylinder



ART. 020

✓ ART. 153 • 154 • 155 • 156 • 154/IP •
155/IP • 156/IP • 154/P • 155/P • 156/P



ART. 021

✓ ART. P30/SA • P30/SAIP • P30/SAP

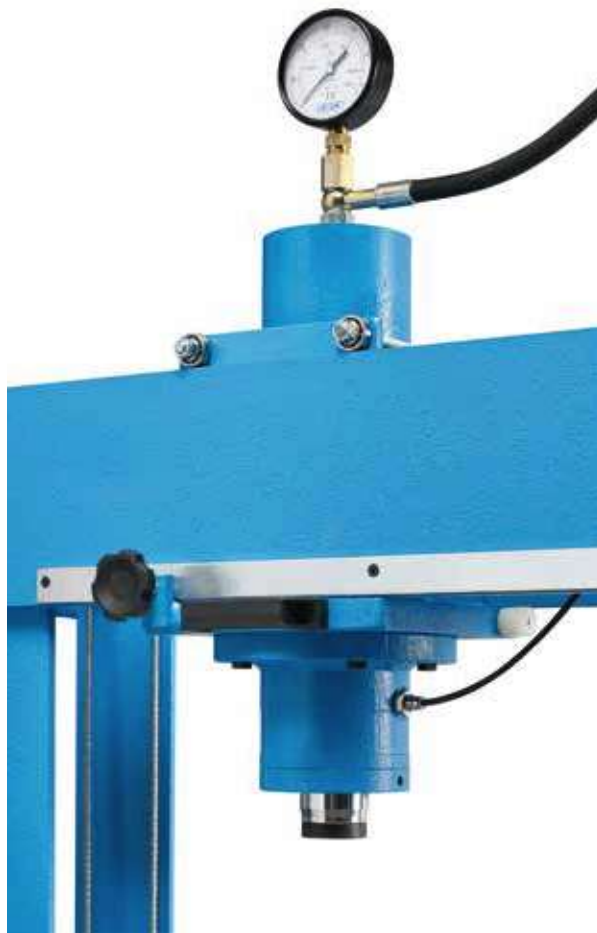

ART. 022*



ART. 162/W • 162/R

ART. 022/A*



ART. 164/W • 164/WS • 164/R • 164/RS

ART. 022/B*



ART. 204/W • 204/R

ART. 022/C



ART. 205/W • 205/R

ART. 022/D



ART. 280/W • 280/R



* Sollevamento del bancale
tramite asta

Shaft to raise the work-
bench

Relevage du plan de travail
par barre

Hebung dem Tisch mittels
einer Stange

- Cinquantennale esperienza realizzativa.
- Oltre settanta modelli di serie con capacità da 6 a 300 ton.
- Esecuzioni speciali per tipologia, dimensioni e capacità.
- Presenza distributiva a livello mondiale.
- La soluzione ideale per le vostre esigenze.

- Fifty-year-long experience.
- Over seventy standard models with capacity from 6 to 300 ton.
- Special executions for typology, dimensions and capacity.
- Worldwide presence.
- The ideal solution for your needs

- Un demi-siècle d'expérience.
- Plus de soixante-dix modèles de série d'une capacité de 6 à 300 ton.
- Réalisation sur demande selon type, dimensions et capacité.
- Présence effective au niveau mondial.
- La réponse idéale à vos exigences.

- Fünfzigjährige Erfahrung.
- Mehr als siebenzig Standard-Ausführungen mit einer Kapazität von 6 bis 300 t.
- Sonderausführungen mit abweichenden Maßen und Kapazitäten möglich.
- Weltweiter Vertrieb.
- Die beste Lösung für Ihre Bedürfnisse.

**SPECIAL
LINE**



PRESSE PER PROVE DI LABORATORIO

PRESSES FOR SAMPLE
LABORATORY TESTING

PRESSES POUR ESSAIS
SUR ECHANTILLONS

PRESSEN FÜR
PRODUKTPROBEN

PRESSE PER STAMPAGGIO

MOULDING PRESSES
PRESSES POUR EMBOUTISSAGE
GESENKPRESSEN

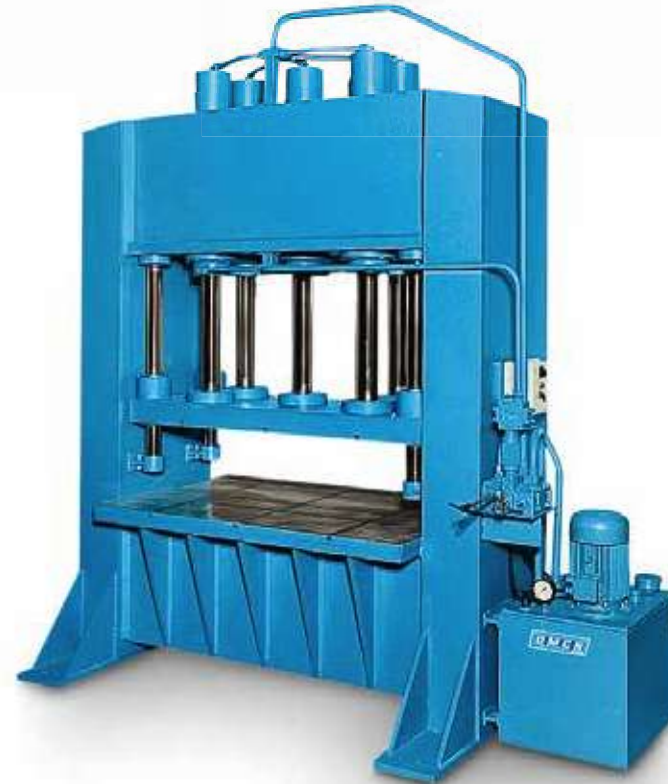



PRESSE PER RADDRIZZATURA

STRAIGHTENING PRESSES
PRESSES DE REDRESSAGE
RICHTPRESSEN

